

FOR SUCCESSFUL TARGETED MARKETING...

you need the clearest view and deepest understanding of your customers and prospects. Throw in some stiff competition, constantly changing customer preferences and online / offline communications – and now you're marketing blind without analytics.



Market Area Mapping

ICS uses state-of-the-art mapping technology to solve complex territorial issues. Some of our client applications include: Metro transportation systems, municipalities with complex resident boundaries and franchise systems with local market area requirements.



Customer Profiling

You can get so much more from your marketing with deeper customer insight. This is very inexpensive (as little as \$1,000) and can dramatically improve your targeted marketing.

ICS can help you gain insight from your customer data ... helping you target your marketing more effectively. Many clients think they know their customer base but are really off the mark.

The profiling process involves appending demographic and lifestyle attributes to your customer base. Through the use of our analysis tools, we can help you better understand age, income, marital status, presence of children, geographic, lifestyle and other variables that will allow you to refine your prospecting efforts.



Segmentation Systems: B2B & B2C

Prospect more effectively by learning from your customer data. ICS has a wide range of analytic tools that identify the strongest demographic or firmographic (business) characteristics of your customers.

For as little as \$1,500, we can help you identify prospects that “look like” your best customers. These techniques have proven to increase prospecting performance and quickly pay for themselves.



Cluster Analysis & Prospect Modeling

Our more advanced methods further improve your prospecting results. These tools once again leverage your customer data ... performing a mathematical evaluation of the characteristics of your customer database.

ICS Analytics offers advanced custom modeling tools that can help you optimize your prospect selection.

Our IBM SPSS Neural Networks modeling tools provide deep-dive, non-linear data modeling procedures that enable you to discover more complex relationships in your data.



The result: Deeper insight and better decision-making

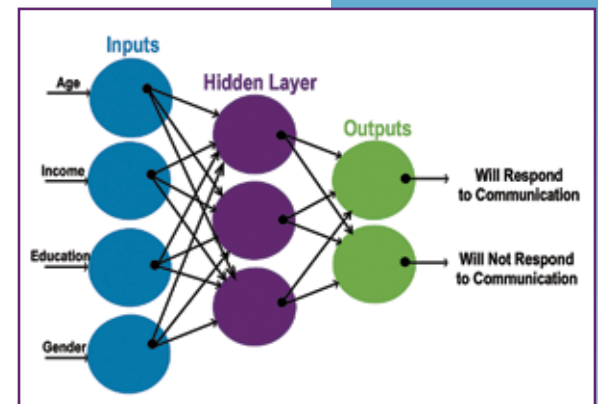

Surveys

ICS provides a turnkey survey process including design, production, scanning and mail operations all the way through to data collection. The result: Strategic and innovative marketing recommendations based on a “deep dive” customer profile and advanced analytics.

Partnered with Cardiff, the leader in data capture tools, ICS offers:

- Web-based survey and paper-based survey systems
- Turnkey solutions, from design consulting to setup of final results assessments.



Analytics, Market Segmentation, CRM, Market Research



*With ICS Analytics,
you can know what happened
and why it happened.*

Now, you can focus your time, effort and budgets on
marketing that works.

Visit www.icshq.com/experience.

See analytics case studies from across multiple industry sectors.
Learn from other marketers' experience to grow your business.

*Client Challenge
ICS Solution
Results*



ICS Marketing Services

Analytics

*Turn Data Into Actionable,
Customer Insight*

We clean, enhance, segment and translate data into meaningful insight that grows your business.

- Marketing becomes more relevant and timely to your customers.
- Turn more prospects into sales.
- Customers become more loyal.
- Increase profitability by identifying customers with high propensity for cross-sales.



*With ICS Analytics,
you can know what happened and why it happened.*

Now, you can focus your time, effort and budgets on
marketing that works.



When You Need to...

- Find & Convert Your Best Sales Leads**
- Integrate Your Online & Offline Marketing**
- Enhance Customer Communication Relevancy**
- Reduce Marketing Costs & Management Time**
- Measure & Optimize Your Marketing Efforts & Prove Increased Sales**

You Need...

ICS Marketing Services
Your Integrated Marketing & Technology Experts



*Analytics, Market Segmentation,
CRM, Market Research*

Connect with us: